

**MODEL:** UJ20-C-V-C-2-SMT-TR | **DESCRIPTION:** USB RECEPTACLE**FEATURES**

- USB Type C receptacle
- USB 2.0
- 480 Mbit/s data transfer speed
- reflow solder compatible
- tape & reel packaging

**SPECIFICATIONS**

| parameter                       | conditions/description  | min | typ    | max                 | units       |
|---------------------------------|---|-----|--------|---------------------|-------------|
| USB standard                    | USB 2.0   |     |        |                     |             |
| rated input voltage             |   |     |        | 20                  | Vdc         |
| rated input current             | as per EIA-364-70, Method B<br>power pins collectively [A1, A4, A9, A12, B1, B4, B9, B12]<br>VCONN pins individually [A5, B5]<br>all other signal pins individually |     |        | 5.0<br>1.25<br>0.25 | A<br>A<br>A |
| contact resistance <sup>1</sup> |   |     |        | 40                  | mΩ          |
| insulation resistance           | at 200 Vdc  | 100 |        |                     | MΩ          |
| voltage withstand               | for 1 minute  | 100 |        |                     | Vac         |
| insertion force                 |   | 5   |        | 20                  | N           |
| withdrawal force                |   | 6   |        | 20                  | N           |
| life                            |   |     | 10,000 |                     | cycles      |
| operating temperature           |   | -40 |        | 85                  | °C          |
| flammability rating             | UL94V-0   |     |        |                     |             |
| RoHS                            | yes   |     |        |                     |             |

Note: 1. When measured at 20 mV / 100 mA.  
2. All specifications measured at 10-35°C, humidity at 45-85%, under standard atmospheric pressure, unless otherwise noted.

**SOLDERABILITY**

| parameter                     | conditions/description      | min | typ | max | units |
|-------------------------------|-----------------------------|-----|-----|-----|-------|
| reel storage                  | at relative humidity 65-70% | 25  |     | 30  | °C    |
| reflow soldering <sup>3</sup> | see reflow profile          |     | 255 | 260 | °C    |

Note: 3. It is recommended to reflow solder within 3 months from opening vacuum packaging at a temperature of 25-30°C & relative humidity 65-70%.

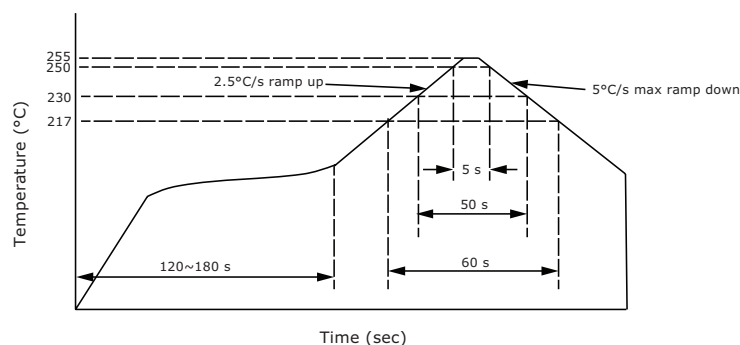

## MECHANICAL DRAWING

units: mm  
 tolerance:  
 X.  $\pm 0.50$  mm  
 X.X  $\pm 0.30$  mm  
 X.XX  $\pm 0.20$  mm  
 X.XXX  $\pm 0.10$  mm  
 unless otherwise specified

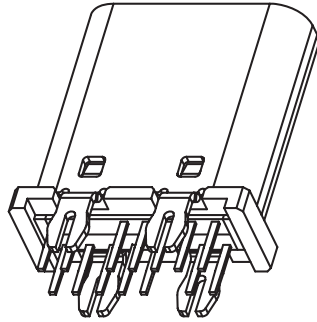

| DESCRIPTION | MATERIAL                     | PLATING/COLOR   |
|-------------|------------------------------|---|
| insulator   | LCP (UL94V-0)                | black   |
| contact     | copper alloy<br>t=0.12 mm    | contact area: gold<br>flash over 50 $\mu$ "<br>nickel<br>solder area: 80 $\mu$ "<br>matte tin over 50 $\mu$ "<br>nickel |
| shell       | stainless steel<br>t=0.30 mm | 50 $\mu$ " nickel   |
| mid plate   | stainless steel<br>t=0.15 mm | 50 $\mu$ " nickel   |

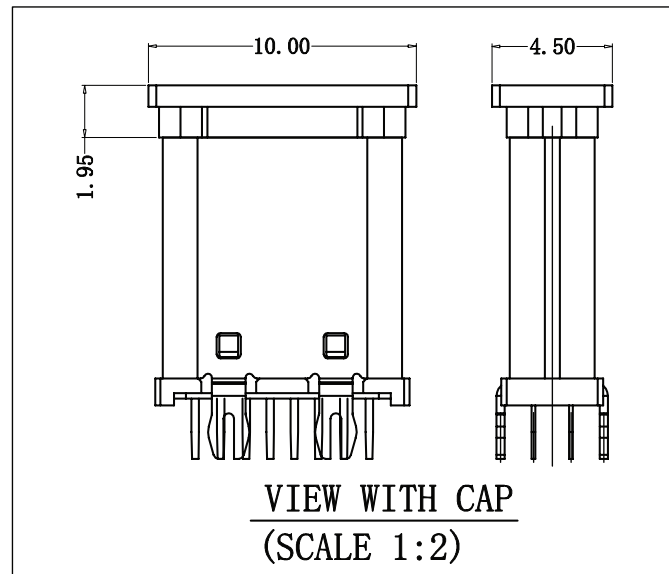
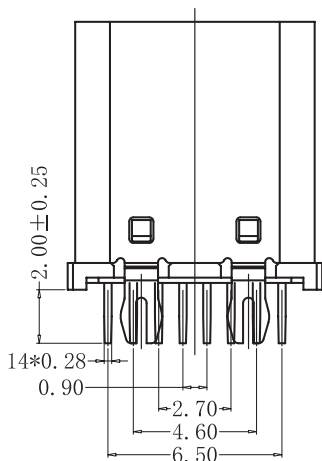
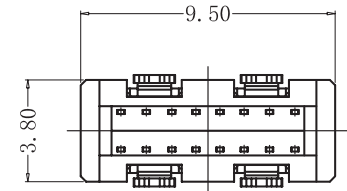
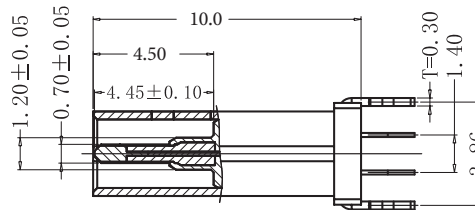
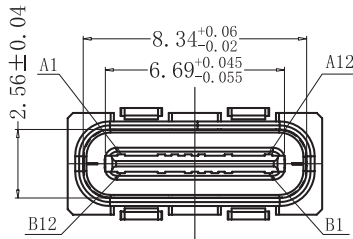
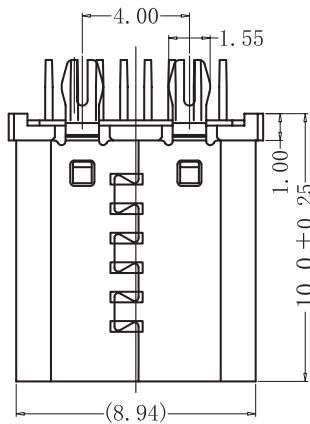

## MECHANICAL DRAWING (CONTINUED)

units: mm  
PCB tolerance: ±0.05 mm

| PIN CONNECTIONS |             |                 |       |             |                 |
|-----------------|-------------|-----------------|-------|-------------|-----------------|
| PIN             | SIGNAL NAME | MATING SEQUENCE | PIN   | SIGNAL NAME | MATING SEQUENCE |
| A1              | GND         | FIRST           | B12   | GND         | FIRST           |
| A4              | VBUS        | FIRST           | B9    | VBUS        | FIRST           |
| A5              | CC1         | SECOND          | B8    | SBU2        | SECOND          |
| A6              | Dp1         | SECOND          | B7    | Dn2         | SECOND          |
| A7              | Dn1         | SECOND          | B6    | Dp2         | SECOND          |
| A8              | SBU1        | SECOND          | B5    | CC2         | SECOND          |
| A9              | VBUS        | FIRST           | B4    | VBUS        | FIRST           |
| A12             | GND         | FIRST           | B1    | GND         | FIRST           |
| SHELL           |             | GND             | SHELL |             | GND             |

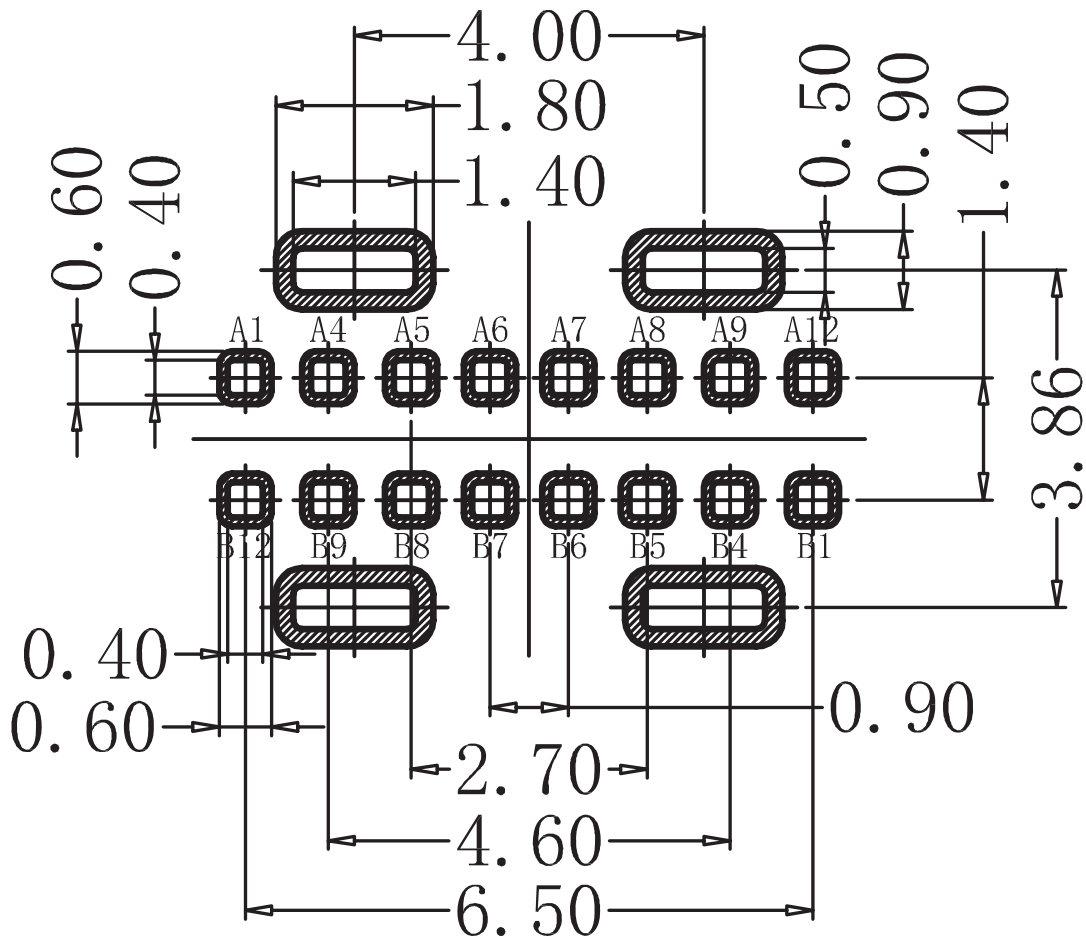

Recommended PCB Layout  
Top View

## PACKAGING

units: mm

Reel Size:  $\varnothing 330$  mm

Reel QTY: 250 pcs per reel

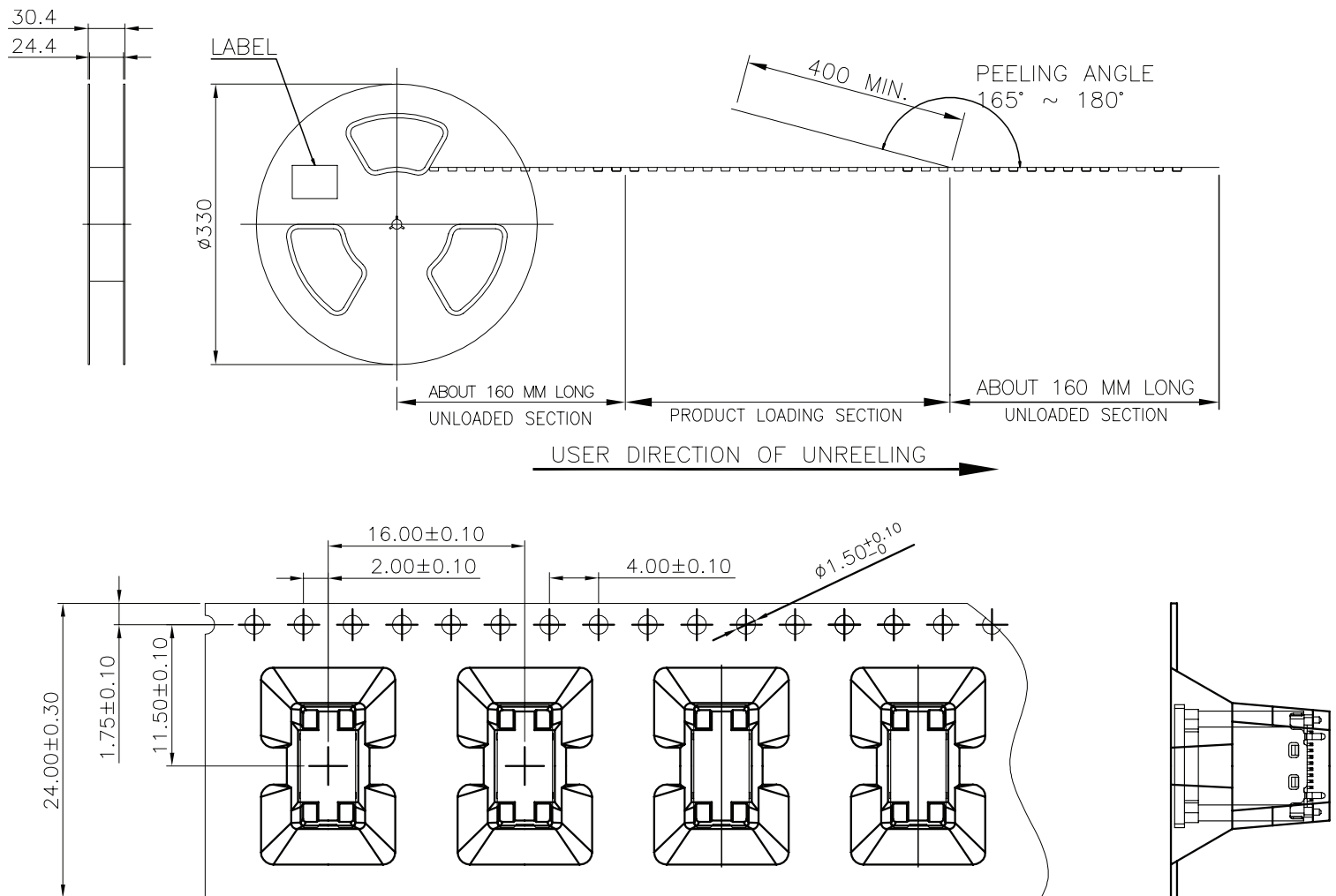

## REVISION HISTORY

| rev. | description     | date       |
|------|-----------------|------------|
| 1.0  | initial release | 05/16/2024 |

The revision history provided is for informational purposes only and is believed to be accurate.



CUI Devices offers a one (1) year limited warranty. Complete warranty information is listed on our website.

CUI Devices reserves the right to make changes to the product at any time without notice. Information provided by CUI Devices is believed to be accurate and reliable. However, no responsibility is assumed by CUI Devices for its use, nor for any infringements of patents or other rights of third parties which may result from its use.

CUI Devices products are not authorized or warranted for use as critical components in equipment that requires an extremely high level of reliability. A critical component is any component of a life support device or system whose failure to perform can be reasonably expected to cause the failure of the life support device or system, or to affect its safety or effectiveness.

[cuidevices.com](http://cuidevices.com)