

Product Change Notice (PCN)

Date: **05/24/2024**

PCN Number: **PCN-0456175R**

To Our Customers:

We appreciate your use of our products. Our commitment in maintaining and improving processes is demonstrated by plans to enhance our product quality, reliability, and manufacturability. The purpose of this notice is to inform you of a product change.

Product(s) Affected: **PJ-082BH**

Reason(s) for Change: **Manufacturing Improvement processes**

Description of Change: **New Factory Location. Product re-engineered for improved manufacturability and production yield. See image below for reference and check CUI Devices website for updated drawing. Cosmetic differences may be visible and not affect the form fit and function of the product.**

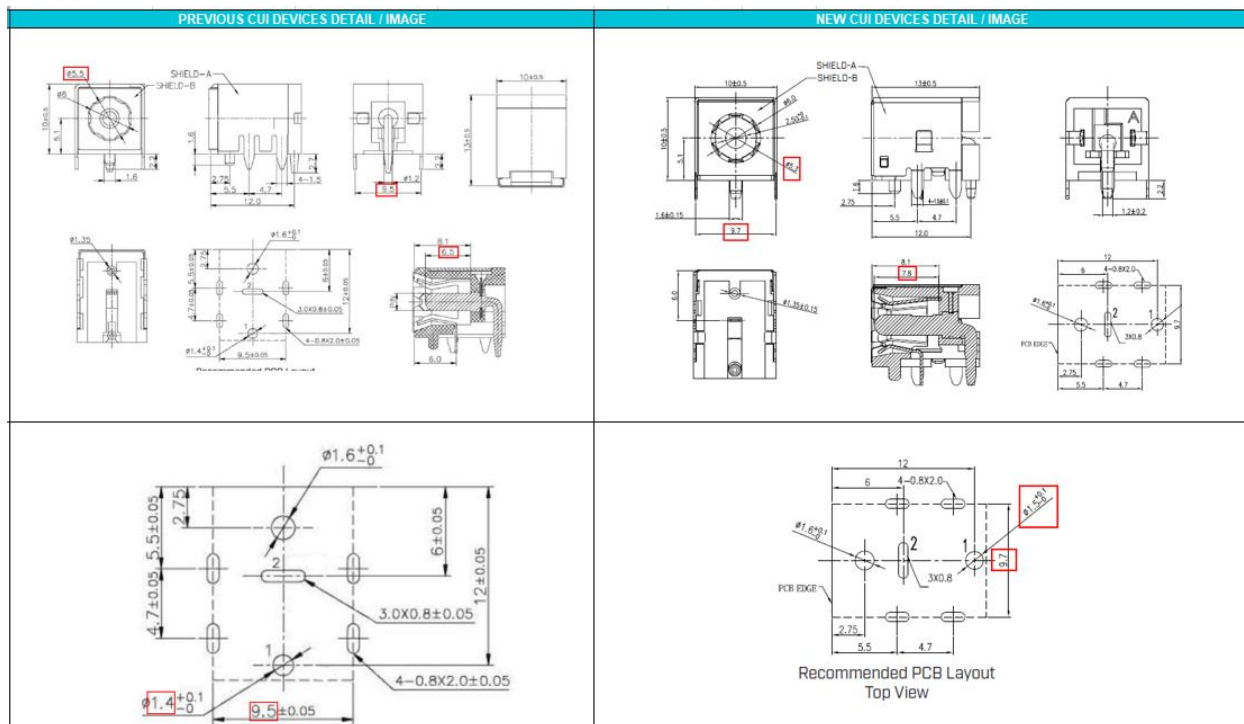

F-723-001

Revision: A



Affected Date Code: All orders placed after **05/15/2024**

Product Availability: *Pertaining to market availability*

PCN Approval:

Operations/Quality

A handwritten signature in black ink, appearing to read "Rose Adams", is written over a horizontal line.

Product Management

A handwritten signature in black ink is written over a horizontal line. The signature is partially obscured by a light gray rectangular box.