

## Product Change Notice (PCN)

Date: **12/20/2022**

PCN Number: **PCN-0450880R-01**

To Our Customers:

We appreciate your use of our products. Our commitment in maintaining and improving processes is demonstrated by plans to enhance our product quality, reliability, and manufacturability. The purpose of this notice is to inform you of a product change.

Product(s) Affected: PJ1-021-SMT-TR

Reason(s) for Change: *Manufacturing process improvements*

Description of Change: *Mechanical, material, soldering, and packaging changes as shown below:*

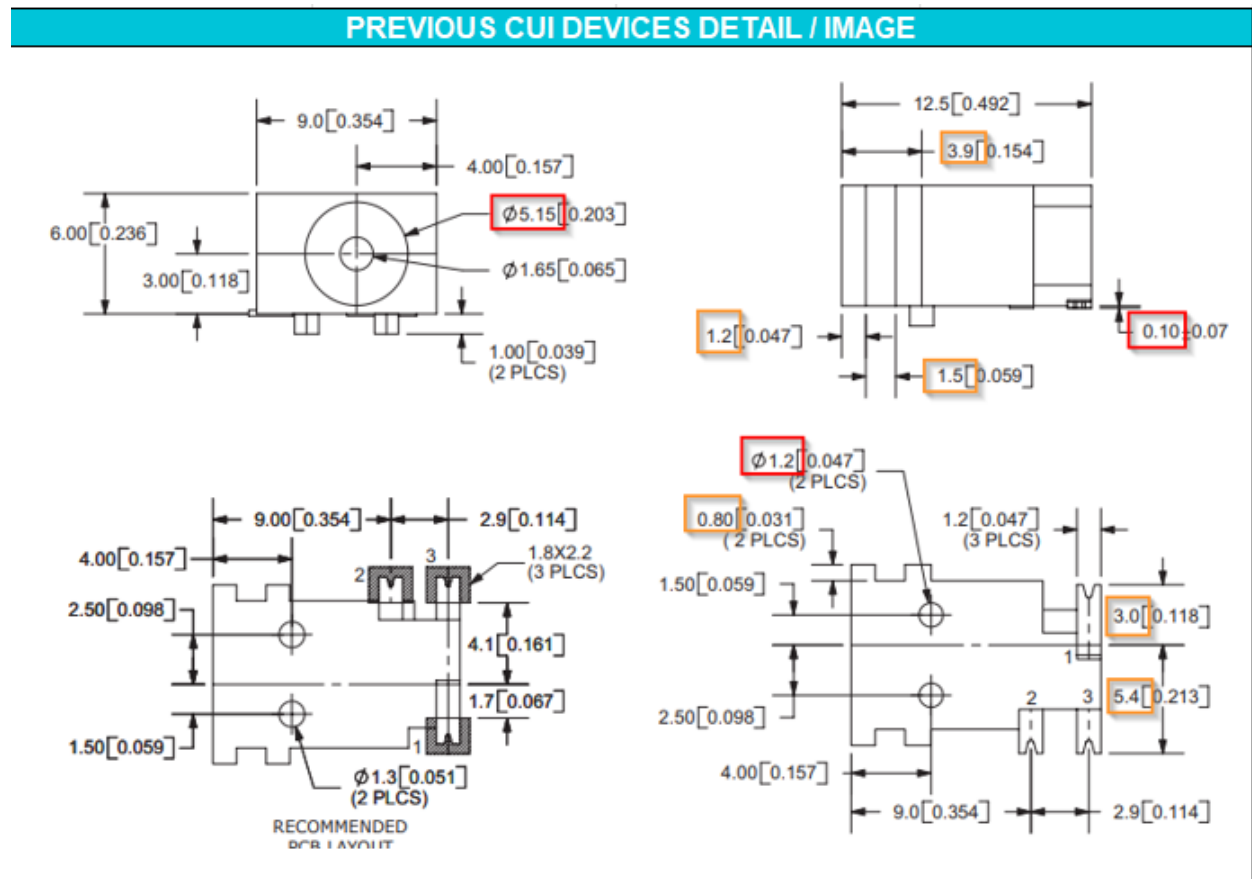

F-723-001

Revision: A

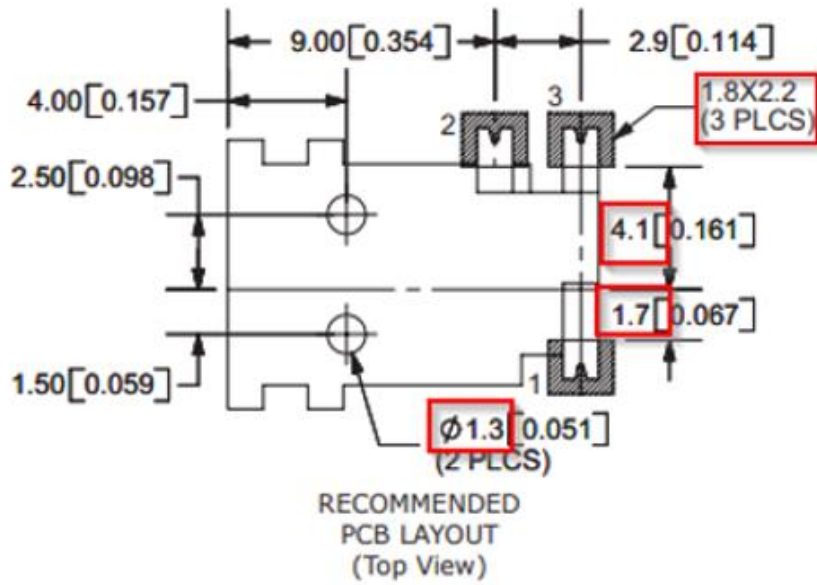

	MATERIAL	PLATING
center pin	brass	silver
terminal 1	brass	silver
terminal 2	copper alloy	silver
terminal 3	brass	silver
plastic	PA6T or equivalent	

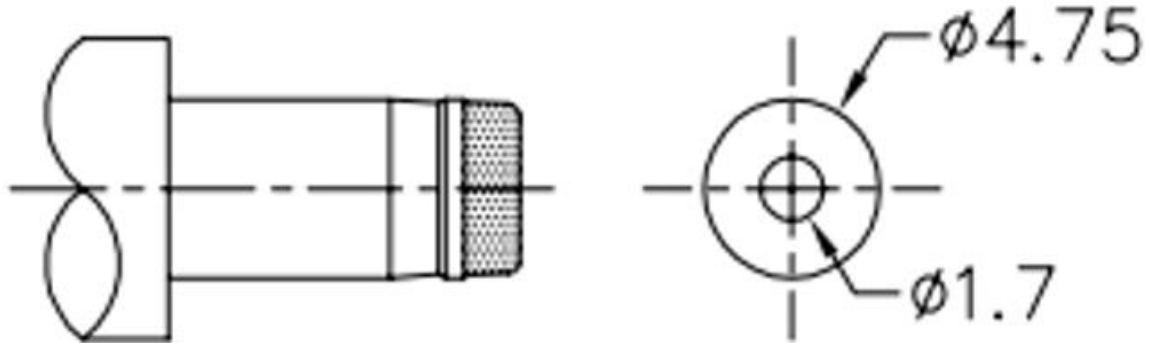

## MATING PLUG

Jack Insertion Depth: **8.0 mm**

### SOLDERABILITY

parameter	conditions/description	min	typ	max	units
reel storage	at relative humidity <80%			40	°C
reflow soldering <sup>3</sup>	see reflow profile	255	260	265	°C
drying conditions <sup>4</sup>	parts in reel: bake at 40°C ±5°C for 72 hours parts removed from reel: bake at 40°C ±5°C for 10 hours				

Note: 3. Must reflow solder within 72 hours from opening vacuum packaging at a temperature <30°C & relative humidity <60%.  
4. When exceeding floor life by >72 hours.

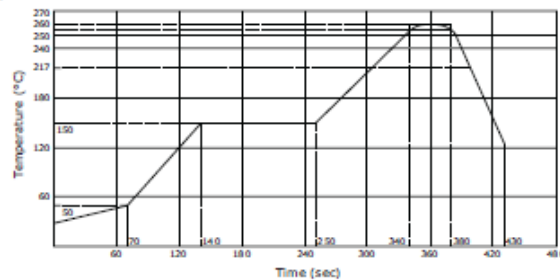

Reel Size: Ø330 mm  
Reel QTY: 500 pcs per reel

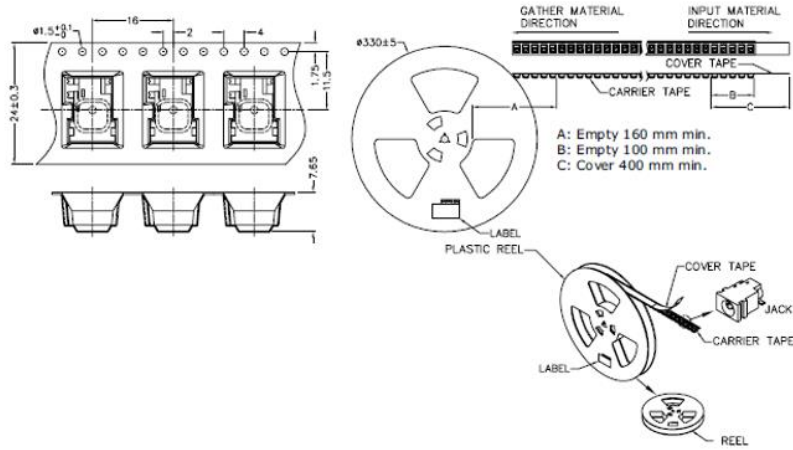

## NEW CUI DEVICES DETAIL / IMAGE

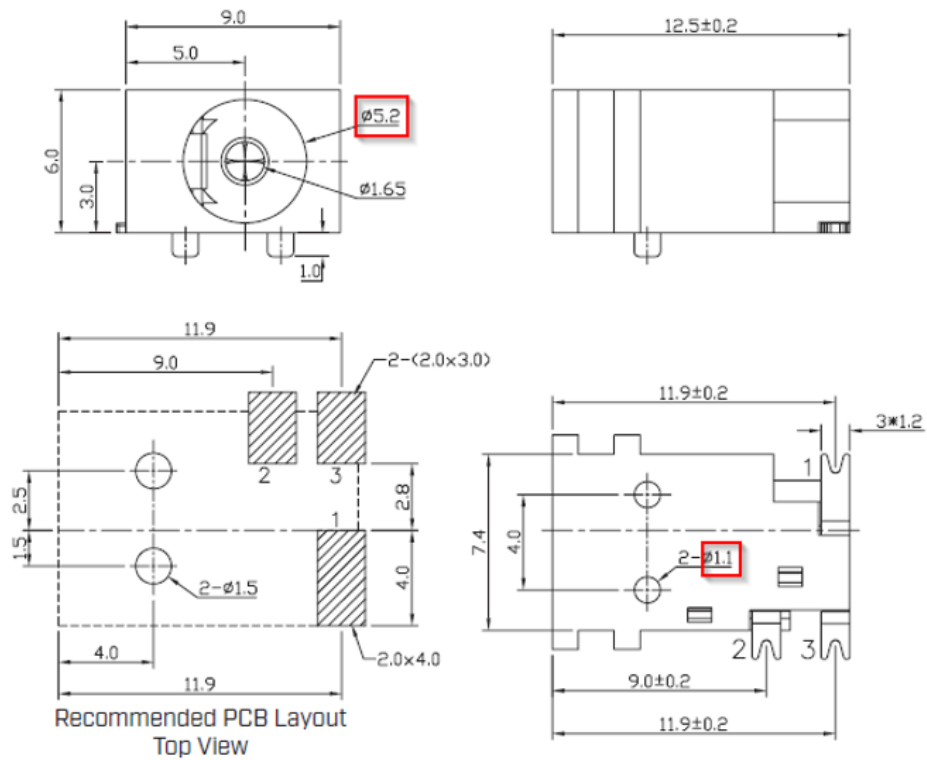

F-723-001

Revision: A

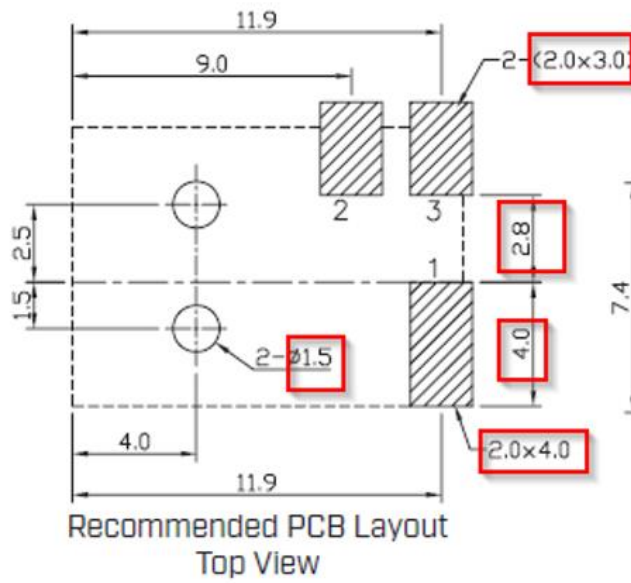

DESCRIPTION	MATERIAL	PLATING
center pin	brass	nickel
terminal 1	brass	nickel
terminal 2	bronze	silver
terminal 3	brass	silver
housing	PA9T (UL94V-0)	black

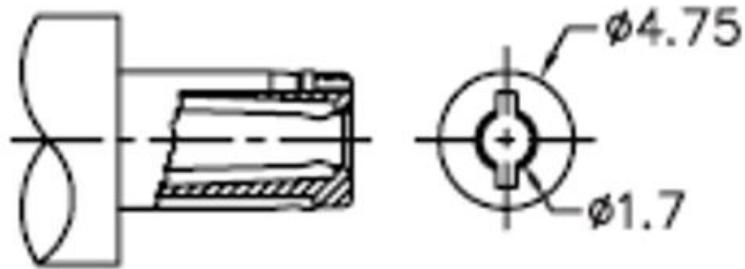

**MATING PLUG**  
**Jack Insertion Depth: 8.1 mm**

### SOLDERABILITY

parameter	conditions/description	min	typ	max	units
reel storage	reel opened & unused parts repacked within 2 hours: $\leq 30^{\circ}\text{C}$ , $\leq 80\%$ humidity reel unopened, 1 year shelf life: $\leq 30^{\circ}\text{C}$ , $\leq 85\%$ humidity				
reflow soldering	see reflow profile			260	$^{\circ}\text{C}$
drying conditions	parts removed from reel over 6 hours: bake at $40^{\circ}\text{C}$ for 6 hours				

Note: 1. CUI Devices recommends usage of the product within 2 hours after TBR is opened. After 6 hours, CUI Devices recommends drying the parts prior to use.

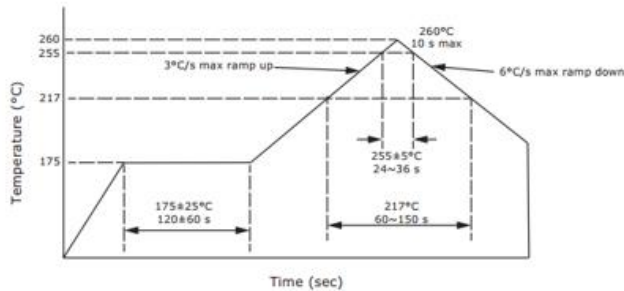

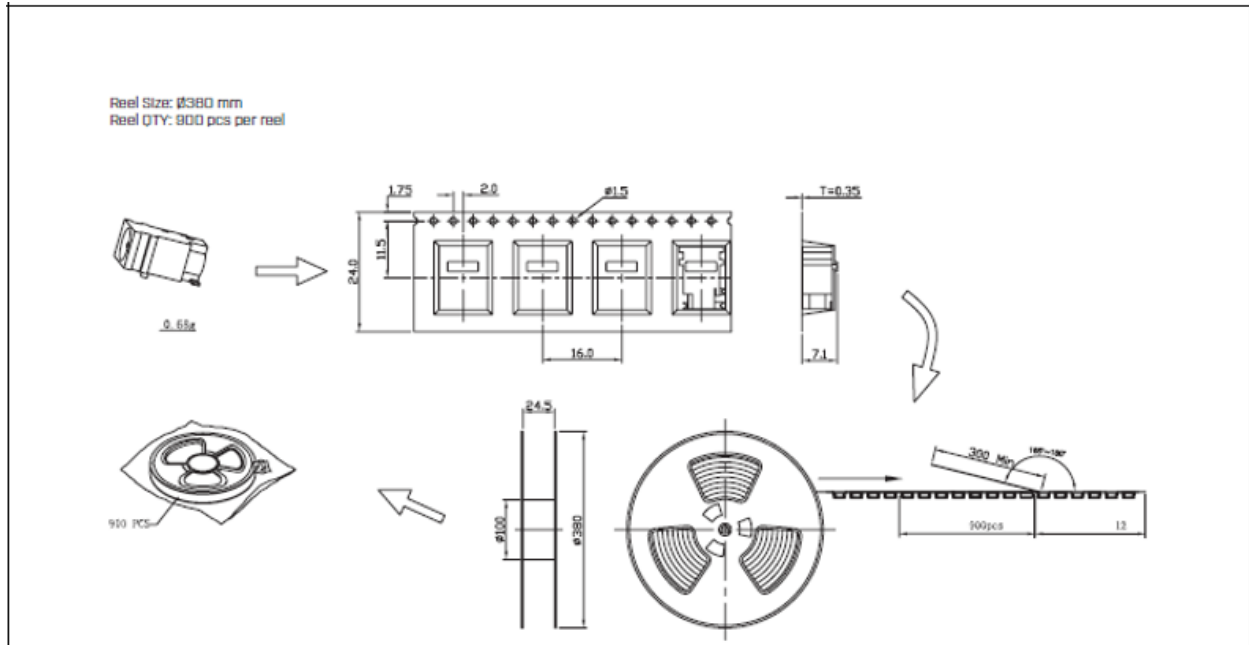

Affected Date Code: *12/8/2022*

Product Availability: *Channel Availability mid Q4*

Additional Information:

PCN Approval:

Operations/Quality

*Roe D. ...*

Product Management

*[Handwritten signature]*

F-723-001

Revision: A



F-723-001

Revision: A