

Product Change Notice (PCN)

Date: 12/19/2016

PCN Number: PCN-0450214R

To Our Customers:

We appreciate your use of CUI products. Our commitment in maintaining and improving processes is demonstrated by plans to enhance our product quality, reliability and manufacturability. The purpose of this notice is to inform you and obtain your approval.

Product(s) Affected:

SD-SN series

Reason(s) for Change:

New tooling for the SD-SN series

Description of Change:

Mechanical dimension changes to connector housing:

Old Housing Dimensions

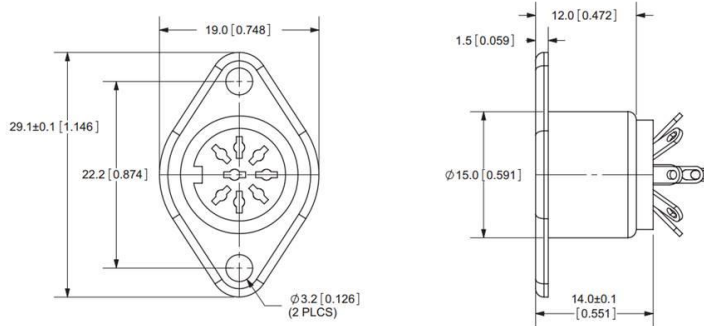

New Housing Dimensions

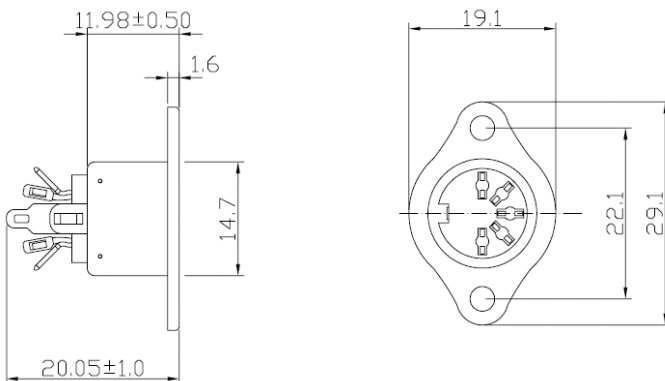



20050 SW 112th Ave. Tualatin, Oregon 97062
phone: 800.275.4899 fax: 503.612.2383
www.cui.com

Affected Date Code:

December 5th, 2016

Product Availability:

Currently available

Additional Information:

No change to product functionality.

PCN Approval:

Operations/Quality: _____

Product Marketing: _____

A handwritten signature in black ink, appearing to be "RU", is written over the signature line for Product Marketing.