

Product Change Notice (PCN)

Date: 03/22/2023

PCN Number: PCN-0450022R-01

To Our Customers:

We appreciate your use of our products. Our commitment in maintaining and improving processes is demonstrated by plans to enhance our product quality, reliability, and manufacturability. The purpose of this notice is to inform you of a product change.

Product(s) Affected: *PJ-074-SMT-TR*

Reason(s) for Change: *Manufacturing Improvement processes*

Description of Change: *Product re-engineered for improved manufacturability and production yield. See image below as reference for product changes. Cosmetic differences may be visible and do not affect the form, fit or function of the product.*

| PREVIOUS CUI DEVICES DETAIL / IMAGE | | | NEW CUI DEVICES DETAIL / IMAGE | | | |
|-------------------------------------|--------------------|------------|--------------------------------|-----------------|-----------------|---------------|
| | MATERIAL | PLATING | | DESCRIPTION | MATERIAL | PLATING/COLOR |
| terminal 1 | brass | gold flash | terminal 1 | brass | brass | gold flash |
| terminal 2 | copper alloy | gold flash | terminal 2 | copper alloy | copper alloy | gold flash |
| terminal 3 | copper alloy | gold flash | terminal 3 | copper alloy | copper alloy | gold flash |
| plastic | PA6T or equivalent | | housing | PA10T (UL94V-0) | PA10T (UL94V-0) | black |

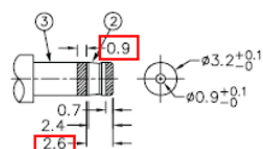
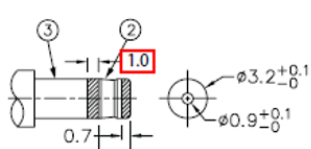
| | |
|--|---|
|  <p>MATING PLUG Jack Insertion Depth: 7.2mm</p> |  <p>MATING PLUG Jack Insertion Depth: 7.0mm</p> |
|--|---|

