

AMT12 SERIES

Assembly Instructions

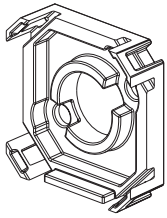

Base

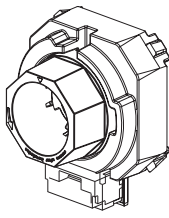

Encoder

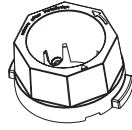

Alignment Tool*



Placement Tool



Centering Tool



Shaft Adapter



Allen Wrench

Sleeve Sizes:

- 1 mm = **White**
- 2 mm = **Light Blue**
- 3 mm = **Orange**
- 3.175 mm (1/8") = **Purple**
- 4 mm = **Gray**
- 4.76 mm (3/16") = **Yellow**
- 5 mm = **Green**
- 6 mm = None Needed

AMT kits come with all items shown.

*Alignment Tool comes pre-installed on all AMT12 Series.

STEP 1

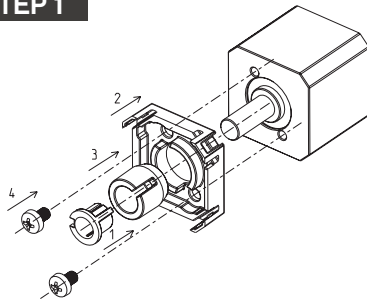

1. Begin by selecting the appropriately sized shaft adapter and insert it into the centering tool. No adapter is needed for a 6 mm motor shaft.
2. Place the plastic base over the motor shaft.
3. Slide the centering tool and shaft adapter over the motor shaft. The centering tool will hold the base in the proper position.
4. While holding the centering tool down in place, install screws to secure the base to the motor body.

STEP 2

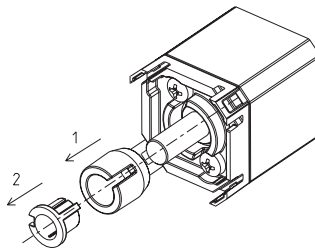

1. Remove the centering tool.
2. Take the shaft adapter out of the centering tool.

STEP 3

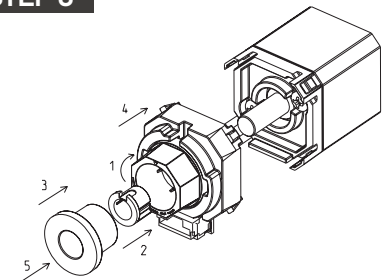

1. Rotate the pre-installed alignment tool clockwise and completely to the right so that the pre-installed shaft set screw is visible.
2. Insert the shaft adapter into the encoder making sure the adapter is properly aligned with the keyway in the metal hub. No adapter is needed for a 6 mm motor shaft.
3. Insert the placement tool into the assembly. This placement tool holds the encoder's hub and shaft adapter in the proper position for installation onto the motor shaft.
4. Position the encoder so it can snap onto the plastic base. The encoder will only snap into place in one orientation.
5. Slide the encoder onto the motor shaft applying force only to the placement tool to maintain proper alignment of the encoder's hub and shaft adapter.
6. Ensure all 4 locking tabs are secured in place over the encoder hub.

STEP 4

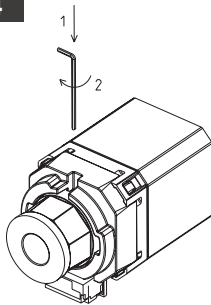

1. Insert the Allen Wrench into the notch on the top.
2. Tighten the shaft set screw. Torque to the specification listed on the applicable AMT encoder datasheet.

STEP 5

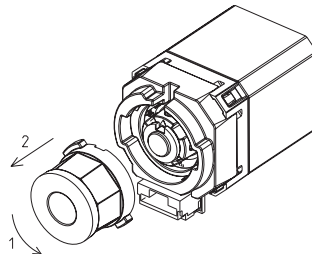

1. Rotate the placement tool and alignment tool counterclockwise until the tabs align with the openings.
2. Remove both tools from the encoder.
3. When installation is finished, the motor shaft should be rotating freely.

For additional instructions or information contact customer support at: 877.323.3576

For more information visit www.cuidevices.com/amt

CUI Devices' products are not intended for applications where a failure could result in costly, dangerous, or life threatening situations. CUI Devices will not be responsible for damages, or losses greater than the cost of the CUI Devices replacement parts.



6405 SW Rosewood St, Ste C
Lake Oswego, OR 97035

© 2022 CUI Devices. All rights reserved.
Information in this document is subject to change without notice.